

AVANT[®]

Operator's Manual for Attachment



3 Point Hitch Adapter

Product number A36433

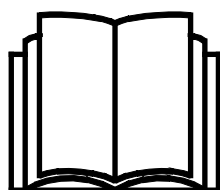

Please read this manual carefully before using the equipment, and follow all instructions.

Keep this manual for later reference.

Manufacturer:

AVANT[®]
AVANT TECNO OY
e-mail: sales@avanttecno.com

Ylötie I
33470 YLÖJÄRVI
FINLAND
Tel. +358 3 347 8800
Fax +358 3 348 5511

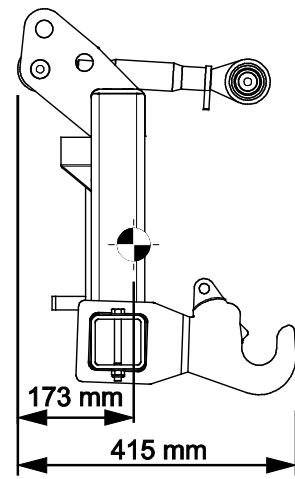
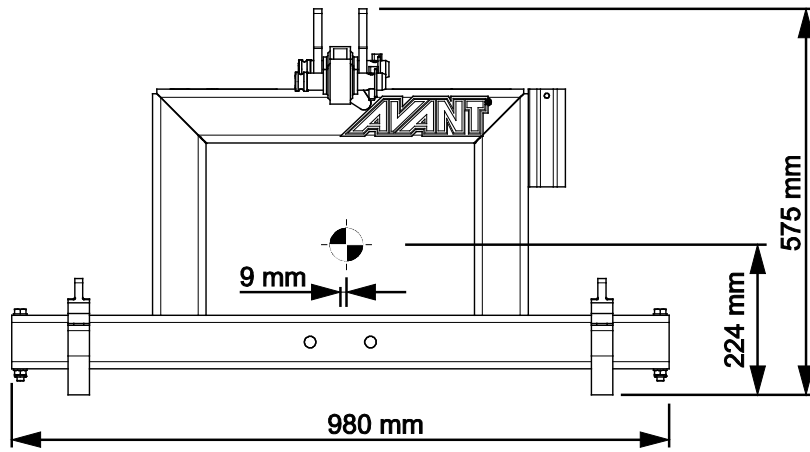

CONTENTS

1. FOREWORD	4
Warning symbols used in this manual	5
2. DESIGNED PURPOSE OF USE	6
3. SAFETY INSTRUCTIONS FOR USING THE ATTACHMENT	7
3.1 Personal protective equipment.....	9
3.2 Safe shutdown procedure	9
4. TECHNICAL SPECIFICATIONS	10
4.1 Safety labels and main components of the attachment	10
5. ATTACHING THE ATTACHMENT	12
6. INSTRUCTIONS FOR USE	14
6.1 Checks before use	15
6.2 Transporting load.....	16
6.3 CAT I adapter kit.....	16
6.4 Working on uneven ground	16
6.5 Transport position	17
6.6 Storing the attachment	17
7. MAINTENANCE AND SERVICE	18
7.1 Cleaning the attachment.....	18
7.2 Inspection of metal structures	18
7.3 Lubrication	18
8. WARRANTY TERMS	19

I. Foreword

Avant Tecno Oy would like to thank you for your purchase of this attachment for your Avant loader. It has been designed and manufactured based on years of experience on product development and manufacturing. By familiarizing yourself with this manual and following the instructions, you ascertain your safety and ensure the reliable operation and long service life of the equipment. Read the instructions carefully before starting to use the equipment or performing maintenance.

The purpose of this manual is to help you to:

- operate the equipment in a safe and efficient manner
- observe and prevent any hazardous situations
- keep the equipment intact and ensure a long service life

With these instructions, even an inexperienced user can use the attachment and loader safely. The manual includes important instructions for experienced AVANT operators as well. Ensure that all persons using the loader have received proper guidance and familiarised themselves with the manual of the loader, each attachment that are used, and all safety instructions before using the equipment. Using the equipment for other purposes or use in any other way than described in this manual is prohibited. Keep this manual at hand throughout the service life of the equipment. If you sell or transfer the equipment, be sure to hand over this manual to the new owner. If the manual is lost or damaged, you can request a new one from your Avant dealer or from the manufacturer.

In addition to the safety instructions included in this manual, you must observe all occupational safety regulations, local laws, and other regulations concerning the use of the equipment. Particularly the regulations concerning the use of the equipment on public road areas must be observed. Contact your Avant dealer for more information about local requirements before you operate the loader on road areas.

Contact your local AVANT dealer for any questions, service, spare parts or about any problems that may occur with the operation of your machine.

This manual contains the original instructions in English. Due to continuous product development some of the details shown in this manual may differ from your equipment. Pictures may also depict optional equipment or features that are not currently available. We reserve the right to change the contents of the manual without notification. Copyright © 2020 Avant Tecno Oy. All rights reserved.

Warning symbols used in this manual

The following warning symbols are used throughout this manual. They indicate factors that must be taken into account to reduce the risk of personal injury or damage to property:



WARNING SAFETY ALERT SYMBOL

This symbol means: **“Warning, be alert! Your safety is involved!”**

Carefully read the message that follows, it warns of an immediate hazard that could cause serious personal injury.

The safety alert symbol by itself and with related safety statement indicates important safety messages throughout this Manual. It is used to draw attention to instructions involving your personal safety or the safety of others. When you see this symbol, be alert, your safety is involved, carefully read the message that follows, and inform other operators.

DANGER

This signal word indicates a hazardous situation which, if not avoided, will cause death or serious injury.

WARNING

This signal word indicates a potentially hazardous situation which, if not avoided, could cause serious injury or death.

CAUTION

This signal word is used when minor injury could result if the instructions are not followed properly.

NOTICE

This signal word indicates information about the correct operation and maintenance of the equipment.

Failure to observe the instructions accompanying the symbol can lead to equipment breakdown or other property damage.

2. Designed purpose of use

The AVANT 3 Point Hitch Adapter is an attachment that is suitable for use with AVANT compact loaders that are shown in Table 1. It is intended for moving agricultural attachments with CAT 2 three point hitch coupling with an Avant loader for storage, cleaning, service shop, or similar occasional, short distances. This can be practical especially when space is limited and handling with tractor is difficult, or tractor is busy with other tasks. The 3 Point Hitch Adapter is not intended for operating tractor attachments.

The 3 Point Hitch Adapter is not designed for any other use than what is specified in this manual and must not be used for any other purposes than what is intended for.

The attachment has been designed to require as little maintenance as possible. The operator can perform regular maintenance tasks. All repair work can't be performed by the operator, and demanding repair and maintenance operations are to be left for professional technicians. All maintenance work must be done using proper safety equipment. Spare parts must be identical with original specifications, which can be ensured by using only original spare parts. A separate spare parts catalogue may be available, consult your Avant dealer.

Familiarise yourself with the manual's instructions regarding service and maintenance. Please contact your AVANT dealer if you have additional questions about the operation or maintenance of the equipment, or if you require spare parts or maintenance services.

Table 1 - 3 Point Hitch Adapter - Compatibility with Avant loaders

Model	220 _{series 2} 225 225LPG	313S 320S	420 423 520 523 R20	525LPG R28 528 530	630 R35 635 640	735 745 750 755i 760i	850 860i	e5 e6
A36433	(●)	(●)	•	•	•	•	•	•

It is recommended to use the attachment only with loaders marked with • in Table 1. When using with models marked with (●), full performance may not be achieved. Additional counterweights may also be required. For compatibility with a model not shown in table, contact your Avant dealer.

3. Safety instructions for using the attachment

Please bear in mind that safety is the result of several factors. The loader-attachment combination is highly powerful and improper or careless use or maintenance may cause serious personal injury or property damage. Due to this, all operators must carefully familiarise themselves about correct use and the operator's manuals of both the loader and the attachment before starting operation. Do not use the attachment if you have not completely familiarised yourself with its operation and the related hazards.



Misuse, careless use, or using an attachment that is in poor condition may cause risk of serious injuries. Familiarise yourself with the controls of the loader, correct coupling procedure, and the correct way to operate the attachment at a safe area. Study especially how to stop the equipment in a safe manner. Read all safety precautions carefully.

Read all safety instructions carefully before handling the attachment



- When attaching an attachment to the loader, **ensure that the locking pins of the loader's quick attach plate are in the lower position and that they have locked the attachment to the loader.** Never lift or move an unlocked attachment.
- This attachment is designed to be used by one operator at a time. Do not let others near the danger area of the equipment when it is in use.
- Always transport the attachment as low as possible to keep the centre of gravity low, and keep the telescopic boom retracted during driving.
- **Sudden movements can cause the loader to tip over - Operate the controls of the loader in a slow and calm manner.** Be careful when lifting load to high level or lifting load from high. Avoid sudden changes in speed or direction to maintain balance of the loader especially when handling heavy loads. Drive slowly and carefully especially on inclined terrain or slippery surfaces.
- **Risk of tipping over - Keep loads close to ground while driving.** Carrying heavy loads can shift the centre of gravity of the loader and lead to tipping over of the loader. For the best stability always transport loads as low and close to the loader as possible, with the telescopic boom completely retracted, to keep the centre of gravity low.
- **Risk of crushing - Never go or allow anyone else to go under the loader boom or attachment.** The stability of the loader may change when leaving the driver's seat, leading to tipping over of the machine. Always remember that the boom may lower unexpectedly due to loss of stability, mechanical fault, or if another person operates the controls of the loader, leading to crushing hazard. The loader is not intended to be left to keep a load elevated for longer periods. Lower the attachment firmly on the ground before leaving the driver's seat and never allow anyone to be under the boom or attachment.
- Keep the loader articulation in straight position when handling heavy loads. When turning the articulation, the loader may tilt forward.
- Observe maximum load indicated in the operator's manual of the loader. Be especially careful when the load sensor indicator is activated, if your loader is fitted with a load sensor system.
- Make sure that the surface can bear the total load. Also follow the correct tyre pressure settings.



WARNING

- Tipping over - Crushing hazard - Do not try to move an unattached attachment by pushing or dragging it, instead, always handle it with the loader.
- Ensure that an unattached attachment is supported properly and can't accidentally move or tip over.
- Pay attention to the surroundings and any other persons and machines moving in the vicinity. Other persons must keep safety distance of 5 meters. Pay attention to the contours of the terrain and other hazards, such as branches and trees that can reach to the driver's area, loose rocks, and slippery surfaces.
- Make sure that overhead clearance is sufficient. Hitting an overhead obstacle may cause the loader to tip over. Keep a safe distance from electric cables, lamps, or other electric systems; hitting live parts may cause electric shock.
- Ensure that ventilation is sufficient when operating indoors. Do not operate the loader in closed spaces regardless of the engine or fuel type. Exhaust gases may concentrate to hazardous levels.
- Never use the attachment to lift or to transport persons or as any kind of work platform even temporarily.
- Make sure to use only an attachment that is in good condition. Check the attachment thoroughly in regular intervals. Do not modify the attachment in a manner that would affect its safety. It is prohibited to drill holes on the attachment, and welding or other means of fixing hooks or other objects on the attachment is strictly prohibited.
- Use the attachment only for its intended purpose. Other use may create unnecessary safety risks, and the equipment may get damaged.
- Make sure that the loader is equipped with necessary safety components, and that they are in working condition. Seat belt must be used. If there are specific hazards related to the operating area, use appropriate safety equipment.
- Also read the safety instructions and correct use of the loader from the operator's manual of the loader.



DANGER

Risk of crushing - Going under the loader boom or an attachment can cause serious injury or death. Never go under the loader boom and prevent others from getting near lifted boom or attachment. Going under a raised attachment or loader boom is dangerous, as the boom may lower due to loss of stability, mechanical fault or when other person operates the controls of the loader. Lower the attachment firmly on the ground to a safe position before leaving the driver's seat.

Keep in mind that the loader boom can be lowered or tilted even if the engine has been shut down (crushing hazard). The loader is not intended to be left to keep a load elevated for longer periods. Always lower the attachment to a safe position before leaving the driver's seat.



3.1 Personal protective equipment

Remember to wear proper personal protective equipment:



- The noise level at the driver's seat may exceed 85 dB(A) depending on loader model and operating cycle. Extended exposure to loud noise can cause hearing impairment. Wear hearing protection while working with the loader.



- Wear protective gloves.



- Wear safety boots whenever working with the loader.

3.2 Safe shutdown procedure

Safe position of the attachment, before going near the loader boom:



WARNING

Always set the attachment to a safe position before going near the attachment.

Safe position will prevent unintentional movements of the attachment and the loader boom. Note that the attachment can move even if the engine of the loader is turned off.

Safe stopping procedure:

- Lower the boom completely down and lower the attachment flat on the ground.
- Shut down the loader engine and lock the parking brake.
- Prevent starting of the machine, remove ignition key.

4. Technical specifications

Table 2 - 3 Point Hitch Adapter - Specifications

Product number	A36588
Type:	ISO 730 CAT 2 3 Point Hitch
Weight:	57 kg
Maximum allowed load:	630 kg
Suitable Avant loaders:	See Table 1
Options	
Towing hitch, pin & 50 mm ball (optional extra):	A417337
CAT 1 mounting kit (optional extra):	A418980

4.1 Safety labels and main components of the attachment

Listed below are the labels and markings on the attachment. They must be visible and readable on the equipment. Replace any unclear or missing label. New labels are available via your retailer or contact information provided on the cover.



Make sure all warning decals are readable. The warning labels contain important safety information and they help to identify and remember the hazards related to the equipment. Replace damaged or missing warning labels with new ones.



A46771



A46772



A46803

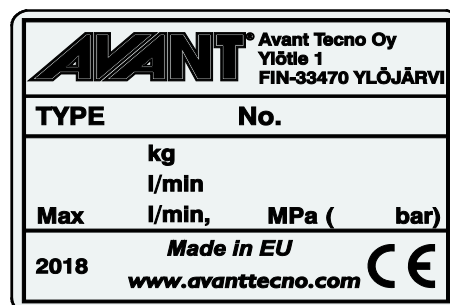

Attachment identification plate
A418915

To apply a new label: Clean the surface thoroughly to remove all grease. Allow it to dry completely. Peel off the protective film of the label and press firmly to apply. Take care not to touch the glue of the label.

Table 3 - Decal locations and warning messages

Decal	Warning message
1 A46771	Misuse hazard - Read instructions before use.
2 A46772	Crushing hazard - Do not go under a raised attachment; stay away from raised equipment.
3 A46803	Pinching and cutting hazard, keep clear of moving parts, do not leave the equipment running. Operate the attachment only from the driver's seat.
4 A418915	Attachment identification plate

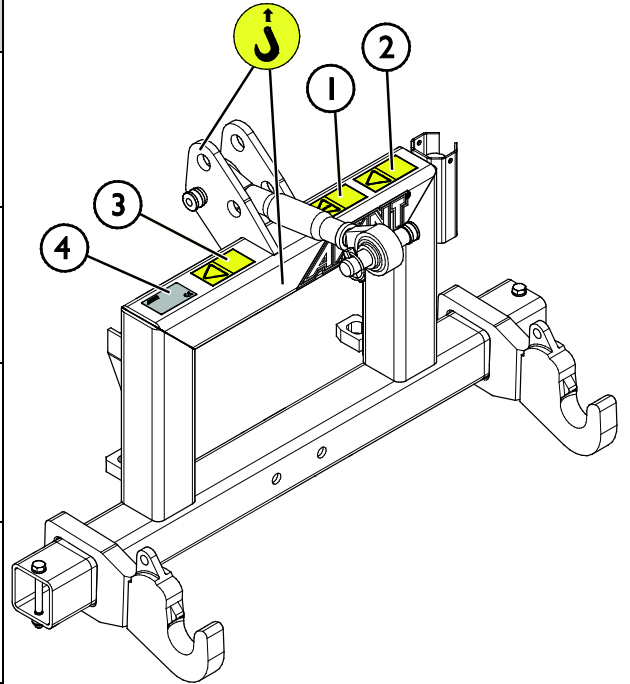
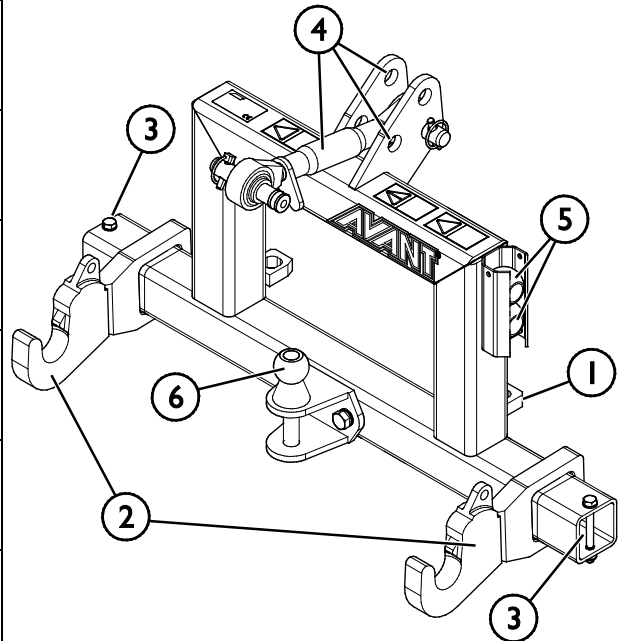

Table 4 - 3 Point Hitch Adapter - Main components

1	Frame with Avant quick coupling brackets
2	Lower link arms
3	Lower link arm retaining bolts
4	Top link and different coupling points for top link
5	Lower link arm balls
6	Towing hitch (optional extra)



5. Attaching the attachment

Attaching the attachment to the loader is quick and easy, but it must be done carefully. The attachment is mounted to the loader boom by using the quick attach plate on the loader boom and the counterpart on the attachment.

If the attachment is not locked to the loader, it may detach from the loader and cause a hazardous situation. The loader must not be driven and the boom must never be lifted when the attachment has not been locked. To prevent hazardous situations, always follow the coupling procedure shown below. Also remember the safety instructions shown in this manual. The attachment is mounted to the loader as follows:

NOTICE

Never mix the oil of the hydraulic system of the Avant loader and third party attachment.

NOTICE

Notice that some third party attachments may have hydraulic oil that is not intended to be mixed with the oil in the hydraulic oil of the loader. Flushing of the hydraulic oil circuit of the attachment may be necessary before coupling to the loader. Incompatible oils can cause wearing of hydraulic pumps and rotors.



WARNING

Crushing risk - Make sure that an unlocked attachment will not move or fall over.

Do not stay in the area between the attachment and the loader. Mount the attachment only on level surface.

Never move or lift an attachment that has not been locked.

Avant quick coupling system:

Step 1:

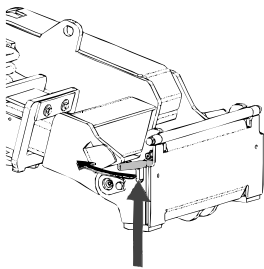

- Lift the quick attach plate locking pins up and turn them backwards into the slot so that they are locked in the upper position.
- If your loader is equipped with a hydraulic attachment locking system, see additional instructions about the use of the locking system from the relevant manuals.
- Make sure that the hydraulic hoses are positioned so that they will not get in between the coupling plate of the loader and the attachment, and that they will not get squeezed or chafed against sharp edges.

Step 2:

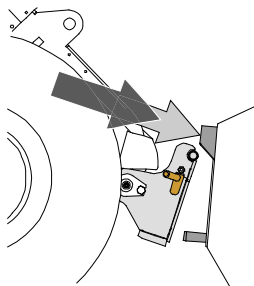

- Turn the quick attach plate hydraulically to an obliquely forward position.
- Drive the loader onto the attachment. If your loader is equipped with a telescopic boom, you can utilise this.
- Align the upper pins of the loader's quick coupling plate so that they are under the corresponding brackets of the attachment.

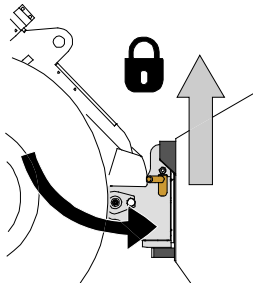

Step 3:

- Lift the boom slightly – pull the boom control lever backward to raise the attachment off the ground.
- Turn the boom control lever left to turn the bottom section of the quick attach plate onto the attachment.
- Lock the locking pins manually or lock the hydraulic locking.
- **Always check the locking of both locking pins.**



Risk of crushing - Avoid tipping over the attachment. Excessive tilting or lifting of an unlocked attachment increases the risk of tipping the attachment over. Do not use the automatic locking of the locking pins when the attachment is lifted more than one meter from the ground. If the locking pins do not return to the normal position when tilting, do not tilt or raise the attachment any more. Lower the attachment on the ground and secure the locking manually.



Risk of falling objects - Prevent dropping of attachment.

An attachment that has not been completely locked to the loader may fall on the boom or towards the operator, or fall under the loader during driving, causing loss of control of the loader. Never move or lift an attachment that has not been locked. Before moving or lifting the attachment, make sure that the locking pins are in the lower position and come through the fasteners on the attachment on both sides.

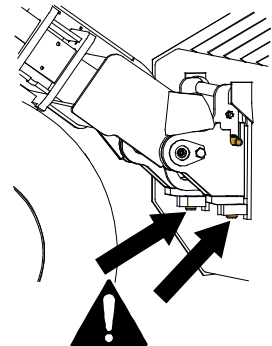

Make sure the loader is compatible with the attachment. Stability of the loader, possible overload of the attachment, and compatibility of loader control systems must be ensured in addition to mechanical compatibility of the attachment. If you use the attachment with a loader that is not fit to be used with the attachment model you have, risks include tipping over, damage to attachment due to overload, and risks related to uncontrolled motion of attachment and its parts. If your loader is not listed in Table 1 on page 6, ask your Avant dealer before using this attachment.

6. Instructions for use

Check the attachment and the operating environment once more before starting to work, and that all obstacles have been removed from the operating area. Quick inspection of the equipment and the operating area before use are parts of ensuring safety and the best performance of the equipment.



WARNING

Risk of tipping over - Avoid overload. Loader can tip over when handling too heavy loads, or because of dynamic movements caused by driving with and handling of a heavy load. Do not extend the telescopic boom when the load approaches the lifting capacity of the loader, or when the loader boom is in horizontal position. When you notice that the rear wheels of the loader are about to lift from the ground, or if the load indicator of the loader (if fitted) signals:

- Lower the load calmly and retract the telescopic boom
- Avoid sudden changes in speed or direction whenever load is lifted
- Use additional counterweights as needed



WARNING

Risk of crushing - Ensure that the parking brake of the loader is engaged when working near the attachment. Use additional blocks if needed. Whenever possible, lower the attachment firmly on the ground.



WARNING

Risk of falling from height and crushing under bucket or loader - Never use a bucket as a lifting platform or to carry people. Never use the loader or its attachments to lift persons or as any kind of work platform even temporarily. Never climb on the attachment.

Always lower the bucket on the ground before leaving the driver's seat. The loader is not intended to hold loads lifted for longer periods of time.



WARNING

Crushing hazard - Risk of tipping over. Make sure the tractor attachment is positively locked to the three point hitch before moving or lifting the attachment. Follow all storage, mounting, and transporting instructions in the operator's manual of the tractor attachment.



WARNING

Risk of tipping over - Avoid overload and keep heavy load close to the loader. Keep loads close to the ground whenever driving, especially during turns and uneven terrain. Pay attention that a heavy load or long distance between the loader and the centre of gravity of the load will affect the balance and handling of the loader. The use of additional counterweights is recommended especially when operating smaller loader models. For 200 series loader the wheel weights are recommended. With heavy loads, the telescopic boom must be kept retracted while moving with the loader. Always wear seat belt.



WARNING

Risk of crushing - Abrupt movements can cause loss of stability. Movements, such as stopping, turning, or lowering the boom abruptly, can cause loss of stability. Always drive slowly and operate the controls of the loader very carefully when handling heavy loads.

6.1 Checks before use

- Use only when all pins are locked and secured in place.
- Check the general condition of the attachment and the loader.
- Check that the top link is intact and in good condition. Do not use damaged equipment.
- Ensure that the ground surface is level and solid enough for safe operation.
- Drive carefully on uneven terrain and note the effect of heavy load at the front of the loader to the stability and handling of the loader.
- Ensure that bystanders are at a safe distance when operating the equipment. Do not let anyone to enter danger area of the boom or to stay directly in front of the loader. Also make sure that it is safe to reverse with the loader. Never assume that bystanders will remain where you last saw them; especially children are often attracted to the moving equipment.
- Operate the attachment and the controls of the loader only when seated on the driver's seat. Ensure that the loader and the attachment are used in a safe manner and as intended. Do not allow children to operate the equipment.
- Never operate the loader or attachments while under the influence of alcohol, drugs, medication that may impair judgement or cause drowsiness, or if not otherwise medically fit to operate the equipment.
- Remember correct working methods and avoid leaving the driver's seat unnecessarily. Practise the use of the attachment and the controls of the loader in a safe area. If you are unfamiliar with the particular loader model, it is recommended to practise its use without any attachments.

6.2 Transporting load

When transporting load with the 3 Point Hitch Adapter, make sure that the load is well balanced and stays firmly. The load must be transported calmly as low and close to the loader as possible, and the swinging of the load must be avoided.

Maximum allowed load for the 3 Point Hitch Adapter is 630 kg. Also refer to the operator's manual of the loader for the safe load of the loader in different operating conditions.

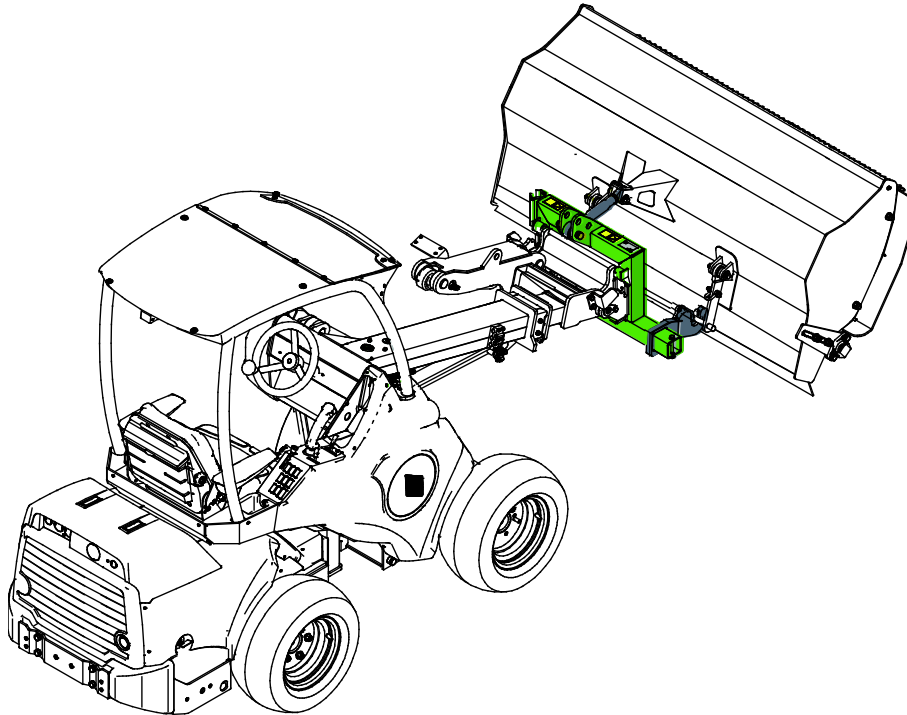

6.3 CAT I adapter kit

To move attachments with CAT 1 three point hitch, the mounting kit A418980 should be used.

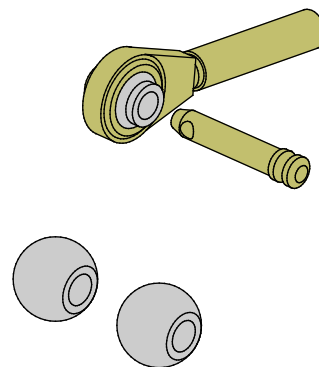

6.4 Working on uneven ground

Extra caution is needed when using the equipment on inclined terrains and slopes. Drive slowly especially on inclined, uneven, or slippery surfaces, and avoid sudden changes in speed or direction. Operate the controls of the loader with careful and smooth movements. Watch out for ditches, holes on the ground, and other obstacles, as hitting an obstacle may cause the loader to tip over.

Maximum lifting capacity can not be achieved on inclined terrain. On horizontally tilted terrain the load must not be lifted high. The loader frame articulation should be kept straight when lifting heavy loads; turning the load during lifting operation will affect the stability of the loader and may lead to overturning of the machine.

6.5 Transport position

Keep the loader stable. Always transport the attachment as low and close to the ground as possible. Keep the telescopic boom retracted during drive.

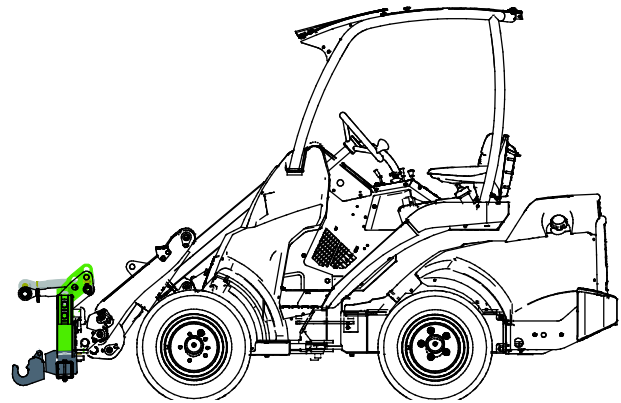

6.6 Storing the attachment

Uncouple and store the attachment on level ground. The best way to store the attachment is in a place where it is protected from direct sunlight, rain, and extreme temperatures.

- Avoid leaving the attachment laying directly on the ground. Place it on blocks of wood or on a pallet, for example.
- Make sure that the attachment is secured against all movements during storage.
- Never climb on the attachment.

For longer storage periods touch up the paint where needed to prevent rust damage.

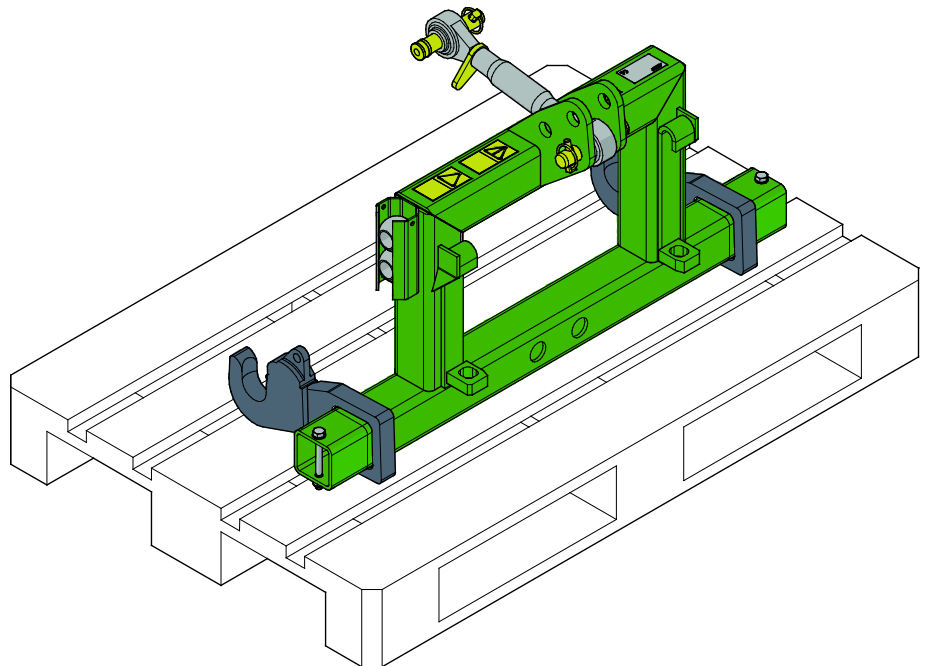

7. Maintenance and Service

The attachment has been designed to be as maintenance free as possible. Continuous maintenance includes regular cleaning and lubrication, and monitoring the condition of the attachment. Because of the crushing hazard caused by lowering machine parts, all maintenance work must be done when moving parts have been lowered down completely and the attachment is lowered flat against the ground.



DANGER

Risk of crushing - Never go under lifted attachment. Make sure the attachment is properly supported during all maintenance work. Never go under a lifted attachment. The loader boom may lower unexpectedly during maintenance causing serious injuries from crushing or impact even when the loader engine is not running. All maintenance and service must be performed when the attachment has been lowered down to a safe position.

7.1 Cleaning the attachment

Clean the attachment regularly to prevent accumulation of dirt which is more difficult to remove. A pressure washer and mild detergent can be used for cleaning. Do not use strong solvents, and do not spray directly at the hydraulic components, or at the labels on the attachment.

7.2 Inspection of metal structures

Also the metal structures of the attachment must be inspected regularly. Check visually for damages and inspect the quick attach brackets and their surrounding area carefully. The attachment must not be used if it is deformed, cracked, or torn.

Welding repairs are only allowed to be carried out by professional welders. When welding, only methods and additives suited for steel used in attachment must be used. For more information about repairs contact your nearest service point.

7.3 Lubrication

There are no specific lubrication points on the attachment. The attachment is maintenance free, except for cleaning, monitoring its condition, and occasional paint retouch if needed.

8. Warranty terms

Avant Tecno Oy grants a warranty of one year (12 months) from the date of purchase for the attachment it manufactures.

The warranty covers repair costs as follows:

- Work costs are covered, if the repair is not performed at the factory.
- The factory replaces any defective components or consumables.

The factory may reimburse the price of components purchased by the customer in special cases that have been agreed in advance.

The warranty does not cover:

- Normal maintenance work or parts and consumables required for it.
- Damages caused by unusual operating conditions or ways of use, negligence, structural changes made without the consent of Avant Tecno Oy, use of non-original parts or lack of maintenance.
- Consequences of a defect, such as interruption of work or other possible additional damages.
- Travel and/or freight costs caused by the repair.



AVANT[®]